



**FEIYU
TECH**

FY-30A Inertial attitude balancer
for multi-rotor control Installation &
Operation Guide



Guilin Feiyu Electronic Technology Co., Ltd

Rm. C407, Innovation Building, Information Industry Park, Chaoyang Road, Qixing
District, GuiLin, CN

www.feiyu-tech.com

Email: feiyutech@yahoo.cn

Dear Pilot,

Thank you for choosing FY30A as your inertial stabilization solution. This manual mainly introduces FY30A firmware for Multi-rotor flight system. Please read this manual carefully before using the system to ensure proper use and operation.

Note:

- To set up and use of FY30A in multi-rotor flight require a certain degree of multi-rotor flight and RC experience.
- If you have never flown a multi rotor aircraft before, we recommend that you don't install this equipment on your own. Please seek assistance from an experienced RC multi-rotor pilot.
- If you are already an experienced multi-rotor pilot, you will find the installation simple. Please follow the instructions as stated in this manual and you won't go wrong.
- Remember, SAFETY ALWAYS FIRST.

If you need any technical support, please feel free to contact us: service@feiyu-tech.com.

INTRODUCTION

FY30A has integrated three-axis gyro and three-axis accelerometer, which controls the aircraft movement in three-dimensional space. FY-30A can be updated to v1.20 for multi-rotor copter.

Aircraft apply

The FY-30A for multi-rotor copter can be used in the following models:

- Quadcopter X-Type
- Quadcopter cross-Type
- Y3-copter
- Any other configuration apply need, please e-mail us: service@feiyu-tech.com.

RC Radio suitability:

The FY-30A has been tested to work well with the following RC system:

- Robbe-Futaba PPM / PCM 1024 / PCM G3 mode, 2.4G systems
- Graupner / JR PPM 8, PPM 12, SPCM mode;
- MPX PPM8, PPM 12 with UNI mode
- any other system with a neutral position of 1.5 ms (standard in most RC Radios).

The FY-30A Operating Mode for multi-rotor copter supports two flight modes :

- ❖ **Mode 1: Auto-Stabilization mode.** In this mode, the FY-30A will automatically command the control surface of the aircraft to maintain level flight all the time(sticks in the middle position). The sticks correspond the roll and pitch attitude angle.The netual position of sticks is 0 degree and the maximum angle is 55 degrees.
- ❖ **Mode 2: 3D Control Mode.** In this mode, the balancer utilizes its 3-axis gyroscope to sense roll velocity and flight attitude. If no input is given by the pilot (sticks in the middle position) the FY30A will lock the current aircraft attitude. This prevents from rolling of the aircraft at the axial plane and maintains its current posture. Therefore, the aircraft can be easily maneuvered to complete a variety of 3D movements with added stability and smoothness.

Switch Setting for FY-30A Flight Modes

a) To activate the different flight modes, use a free Receiver channel (e.g. Channel 5) to output the appropriate signal to FY30A.

b) Use a 2 way-switch from your RC radio as in the example below:



Switch setting example

RC Receiver Signal output:



Flight Modes	MODE 1	MODE 2
Receiver signal output	900-1800uS	1800-2100uS
FY30A Function	Auto Stabilization mode	3D Mode

c) If you do not connect the Switch channel with your RC Receiver or FY-30A does not detect any incoming signal through this input channel, it will automatically engage Mode 1- Auto Stabilization Mode. However, we do not suggest flying the unit with no signal input to the Switch Channel.

d) Please note that even though there are Throttle Input and Throttle Output from the FY30A, the system does not control the Throttle to hold the altitude, you must always control the Throttle to keep flying altitude.

FY-30A interface for multi-rotor

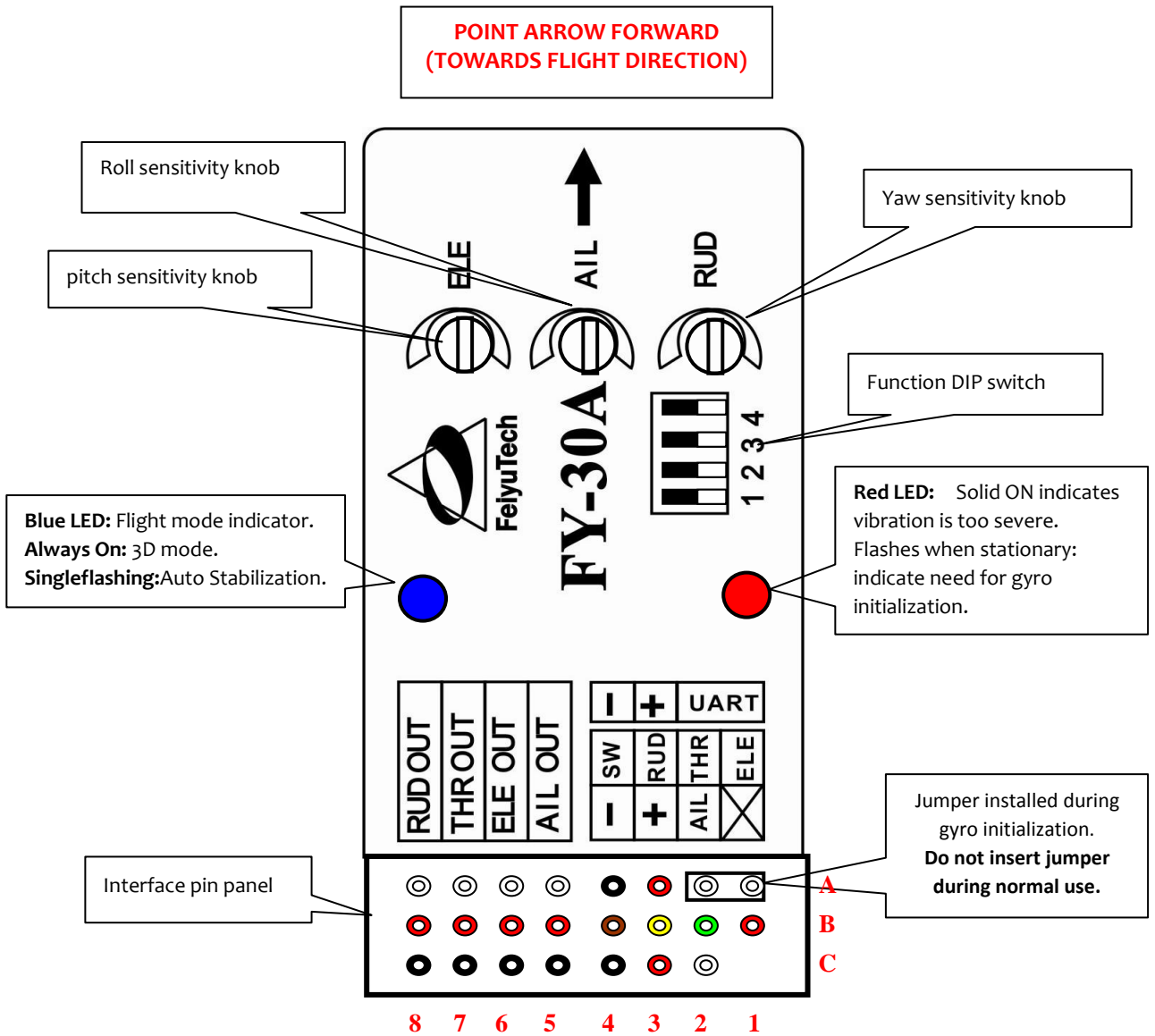

Pin interface to sort the list

8	7	6	5	4	3	2	1	No.
ESC4 out	ESC3 out	ESC2 out	ESC1 out	Ground	Power	TX	RX	A
Power	Power	Power	Power	CH5 (Switch)	CH 4 (Rudder)	CH 3 (Throttle)	CH 2 (Elevator)	B
Ground	Ground	Ground	Ground	Ground	Power	CH 1 (Aileron)	NULL	C

DIP Switch Function:

Switch number	1	2	3	4
ON	For Factory use only	Flight Mode Selection	Flight Mode Selection	Not used
OFF	Always OFF position	Flight Mode Selection	Flight Mode Selection	Not used

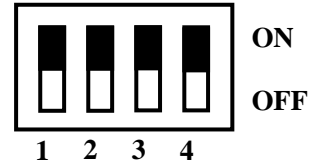

Blue LED

Blue LED	Continuous flashing	On Solid
Flight Mode Status	Auto Stabilization	3D Mode

Red LED

Red LED	OFF	Aircraft is stationary but Red LED Flashes	ON Solid
Status Indicator	Normal	Need to initialize the gyro/ moving	High Vibration Detected. Does not meet system requirement.

Gyroscope initialization (re-setting):

Out of the box, the FY-30A has been fully initialized. However, if the following condition occurs, resetting the gyro is recommended:

1. The device is kept unused for a long time.
2. There is a change in environmental temperature of over 30 degrees.
3. The red LED light flashes even when the aircraft is stationary.

Initialization / Reset Procedure

Install the jumper as shown in this picture:

Power-ON the FY-30A and keep it stationary for at least 20 seconds. You will notice the red light blinks at two different rates (or turns off). Re-setting of Gyro is completed. Disconnect power, unplug the jumper and keep it in a safe place for future use).

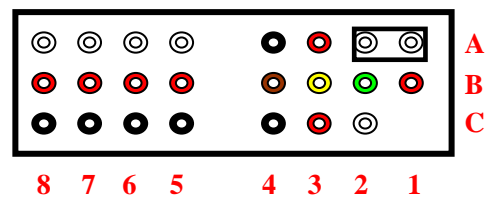

NOTE:

- Carry out this re-setting procedure only if the condition (above) occurs. It is not recommended to regularly reset the gyro. It is not necessary.
- The stabilizer unit does not need to be in a horizontal position during initialization. However, you must ensure there is no vibration during this process. If you suspect shaking has occurred, just restart the resetting process.

FY30A power supply

- FY30A working voltage = 5 to 6V.
- The FY30A requires stable power input. Therefore, we highly recommend using an external BEC power supply with minimum 3A output. The higher the better.
- Be sure to remove the Red wire from your ESC plug if using an external BEC.
- BEC should be plugged into your RC Receiver. Power is sent to the FY-30A via Channel 1 input.
- FY-30A colour coded cable to RC Receiver:



RC Receiver Requirement

- FY-30A requires at least a 5-channel receiver
- Plug in the cable into the FY30A and connect to the RC Receiver following these colour codes:

Wire color	Receiver channel	
White (red and black)	Aileron	Channel 1
Orange	Elevator	Channel 2
Green	Throttle	Channel 3
Yellow	Rudder	Channel 4
Brown	Controlled 2-Way switch	Channel 5

- Note Channel 5 will output the signal to control the 2 flight modes of the FY-30A. Therefore assign 2-way switch to this channel.

QUADCOPTER SET UP

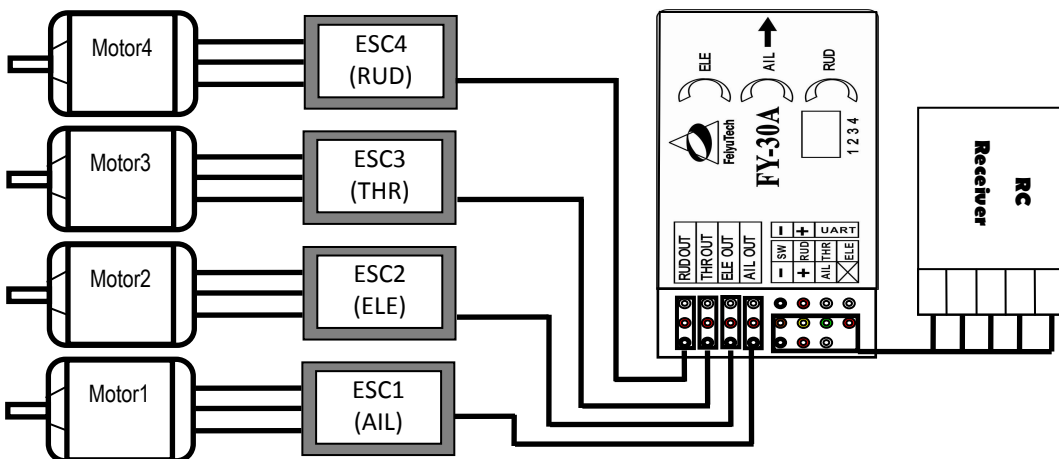

X-Type Layout

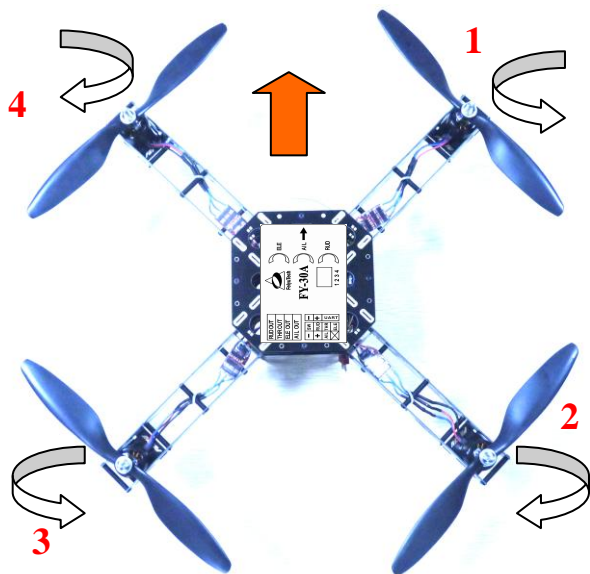

X-Type QuadCopter Layout:

- 1** = ESC 1 CCW
- 2** = ESC 2 CW
- 3** = ESC 3 CCW
- 4** = ESC 4 CW

cw = clock wise
ccw = counter clockwise

Cross Type Layout

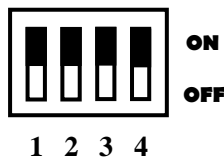
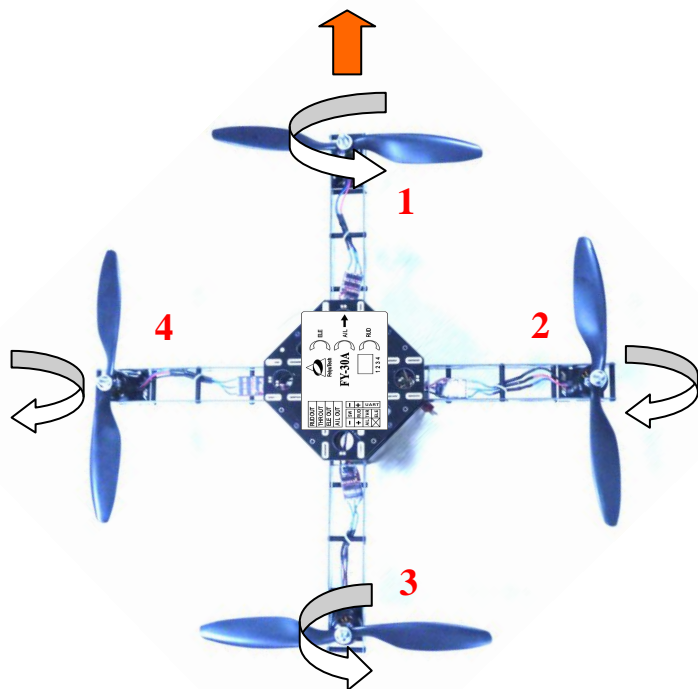

+ - Type Quad Layout:

- 1** = ESC 1 CCW
- 2** = ESC 2 CW
- 3** = ESC 3 CCW
- 4** = ESC 4 CW

cw = clock wise
ccw = counter clockwise

The knob for Quadcopter

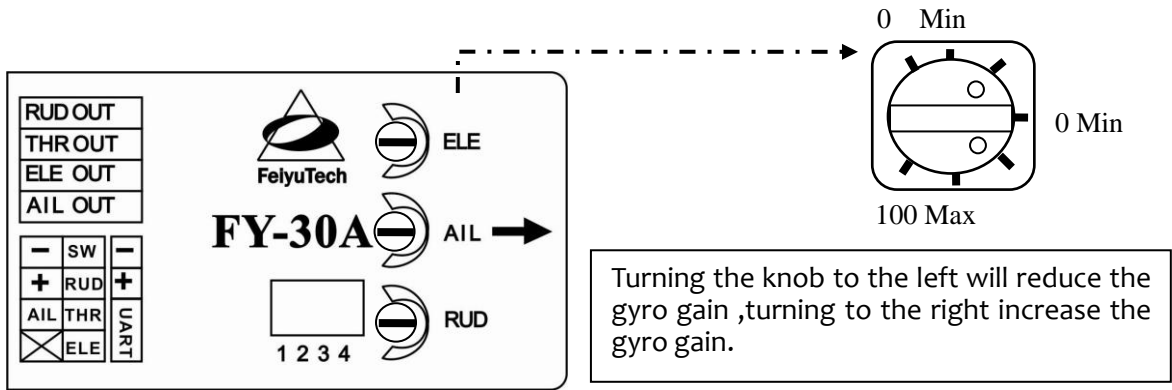

Y3-COPTER SET UP

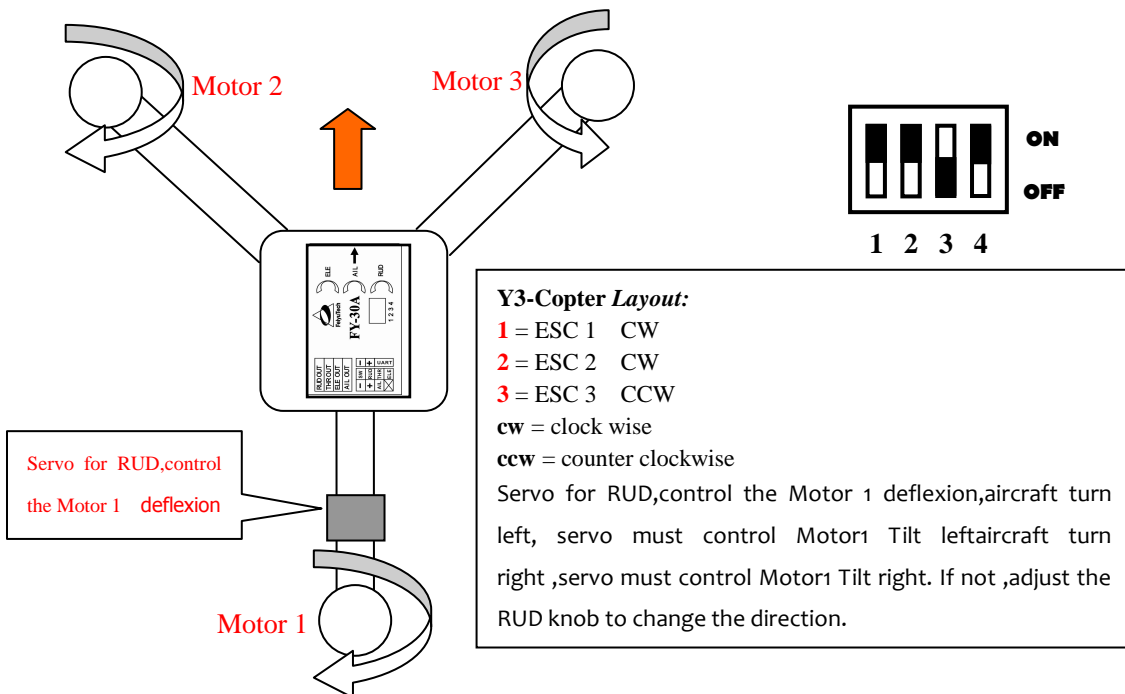
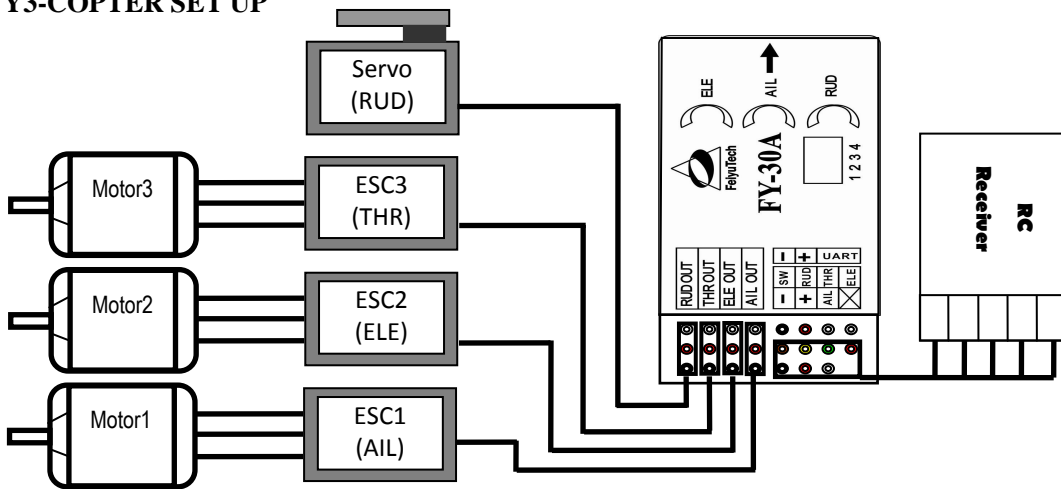

The knob for FY-30A

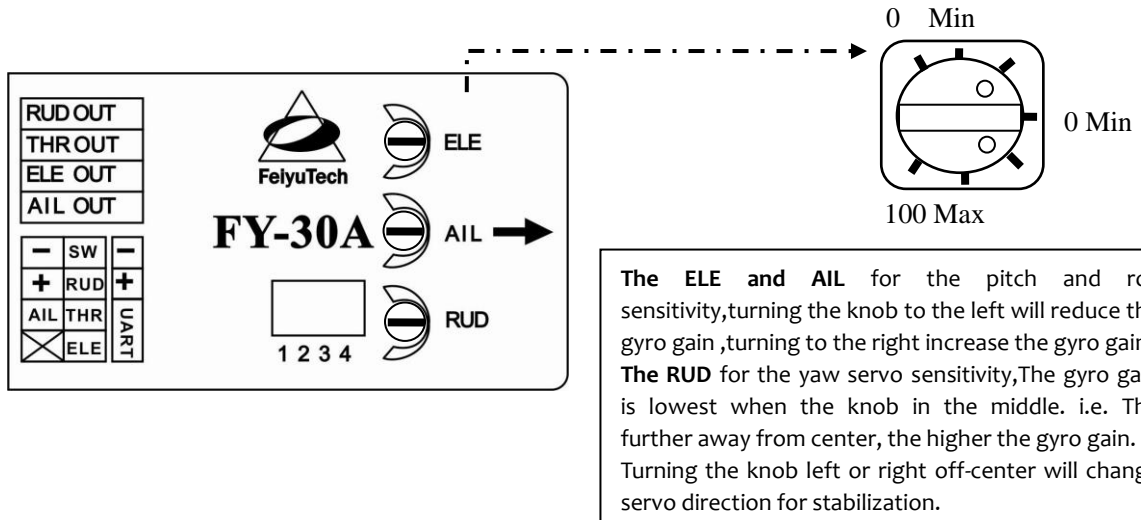

FY-30A Module Installation

1. FY-30A has an arrow indicator on top. Please ensure this arrow is pointed towards the direction of flight.
2. Installed the module horizontally, and as close as possible to the aircraft center. A more centered installation will result in more stable drift free of hover.
3. The FY-30A sets its own benchmark of what is 'horizontal'. Install the module based on the hover characteristics of the aircraft in Mode 1 (Stabilized Mode). Shimming the module may be required to get the aircraft to hover perfectly.
4. You may also fine tune the stability of your aircraft using your radio Aileron, Elevator and Rudder trims to counter any drift.

VIBRATION DAMPING

- a) The FY-30A flight controller algorithms can filter and operate under normal vibration levels, however if the vibration and shock experienced by the onboard sensors is too big, stabilization can fail and the system can shut down altogether.
- b) Because of this, to achieve the best stabilization and flight performance out of the FY-30A, you must minimize the amount of vibration on the aircraft as best you can.
- c) Examples of vibration reduction steps that can be taken:
 - i) Ensure your motors are mounted properly and squarely.

- ii) Balance your propellers regardless of the manufacturer's claim of perfect balance out of the factory.
 - iii) Balance your motor bell housing (if possible).
 - iv) Ensure rigidity of your frame (will not flex with motor rotation).
 - v) Use appropriate propeller length and pitch for the weight of your aircraft.
- d) The FY-30A is supplied with the shock absorbing mount and double-sided foam padding dampers. Please use them as shown below:



CHECKING FOR VIBRATION

- a) Install the FY-30A as per the recommendations of this manual, including directions of propeller rotation.
- b) Throttle up in Mode 1 (*Auto Stabilized Mode*) but **do not take off!**
- c) Observe the red LED on the FY-30A module.
- d) If the red LED light remains OFF, this indicates your aircraft vibration level is acceptable.

Instead, If the red LED light still goes ON and remains lighted, your aircraft does not meet the vibration level requirement. Please take action to reduce the onboard vibration level.

FY-30A Preflight Inspection and Initial Testing

Pre-flight testing for aircraft control:

1. Adjust all stick trims to the middle, Remove all propellers.
2. Activate throttle to start up the motors. Check the rotation direction of each motor and make sure it is turning in the right direction.
3. Re-Install propellers.
4. Check again that the rotation is correct.

5. Check the FY-30A sensitivity control knobs. Please ensure the dials are beyond 12 o'clock. Anything less than that may result in no flight stability for this first flight.
Tie down test: Before proceeding, we highly advise that you tie down the aircraft to the ground to prevent from any possibility of going out of control during this initial flight tests.
6. **First test lift off:** Advance your throttle stick, but do not take off (usually around 30% throttle). Let the aircraft float just enough so that you can see the aircraft reaction as you move your Aileron, Elevator and Rudder sticks.
7. If the control movement is reversed, just reverse the channel on your RC transmitter.
8. After step 7, you can take off higher. If the aircraft hovers well, you can proceed to remove the aircraft from the tie down test.
9. Observe the flight for stability and oscillations as the aircraft hovers higher.
10. If you feel there is not enough stability (e.g. excessive drifting), you can increase the sensitivity of the three dials.
11. If there are rapid oscillations, reduce the corresponding sensitivity knob.
12. More fine tuning adjustment can be done via the FeiYu software (you will need the TTL-USB cable for this).

Pre-flight Debugging

1. If your aircraft fails to lift off and hover for the initial pre-flight tests, please check the following:
 - a) Check whether the connection of ESCs is all correctly plugged in. Take time to check and re-check that each ESC has been plugged in and that the plugs are correctly placed.
 - b) Please ensure there is no short circuit of the power (positive) and GND wires. Short circuits can damage the internal processor chip which is beyond repair (voiding all warranty).
 - c) Check that all motors are rotating in the direction noted in this manual.
 - d) Ensure you have selected low timing for your ESC (if you are not using FY ESCs).